

SkelCap

supercapacitor

- + Capacitance 3200 F
- + Extreme power density
- + Durable and safe aluminum casings
- + Weldable terminals*
- + High cycle life >1,000,000 cycles
- + High temperature tolerance (operating and storage)
- + German quality
- + RoHS compliant
- + UL certified



General	Value	Unit
Rated voltage V_R	2.85	V
Surge voltage V_s	3.0	V
Rated capacitance	3200	F
Specific energy	6.8	Wh/kg
Product code	6710038	
DC 10ms ESR rated	0.14	m Ω
DC 1s ESR rated	0.18	m Ω
Maximum peak current, for 1 second ^{1,9}	2.89	kA
Leakage current (At 2.85 V, 25 °C and 72 hours, max)	11.0	mA

Standards and certifications

Vibration Specification	ISO 16750-3, Table 12
Certifications	RoHS, UL 810A

Physical parameters

Mass, typical (\pm 3-6 g, from small to large size)	0.53	kg
Volume	0.390	L
Diameter (\pm 0.2 mm, including label), D1	60.2	mm
Length (\pm 0.3 mm), L1	138	mm
Terminal diameter, D2	12	mm
Terminal length, L2	3.2	mm

Power	Value	Unit
Nominal power, calculated from 10ms ESR (for comparison)		
Specific power, matched impedance ⁶	27	kW/kg
Power density, matched impedance ⁷	37	kW/L

Nominal power, calculated from 1s ESR (for engineering)

Power, matched impedance ⁵	11.3	kW
Specific power, matched impedance ⁶	21	kW/kg
Power density, matched impedance ⁷	29	kW/L

Temperature and Life

Operating temperature range

Minimum	-40	°C
Maximum	+65	°C

Storage temperature range (uncharged)

Minimum	-40	°C
Maximum	+50	°C

Life

Lifetime @ V_R and +65 °C Capacitance decrease 20% against rated value; 1s ESR increase 100% against rated value	1500	Hours
Storage life @ RT, uncharged	10	Years
Cyclelife @ RT, between V_R and $V_R/2$	1,000,000	Cycles

Energy	Value	Unit
Energy ²	3.6	Wh
Specific energy ³	6.8	Wh/kg
Energy density ⁴	9.3	Wh/L

Safety

Short circuit current (For informational purposes - do not use as operating current.)	20.4	kA
---	------	----

Thermal (based on DC 1s ESR)	Value	Unit
Thermal resistance given $\Delta T = 30^{\circ}\text{C}$, R_{th}	3.0	$^{\circ}\text{C}/\text{W}$
Thermal capacitance, C_{th} , typical	633.7	$\text{J}/^{\circ}\text{C}$
Max continuous current ¹⁰ , $\Delta T = 15^{\circ}\text{C}$ ⁸	167	A
Max continuous current ¹⁰ , $\Delta T = 40^{\circ}\text{C}$ ⁸	273	A

Package details	Value	Unit
Package quantity	25	pcs
Package weight	14.1	kg
Package height	170	mm
Package width	395	mm
Package depth	395	mm

$$(1) \text{ Maximum peak current (1 sec)} = \frac{\frac{1}{2} CV}{C \times \text{ESR} + 1\text{s}} \quad (2) E_{\text{stored}} = \frac{\frac{1}{2} CV^2}{3600} \quad (3) E_{\text{max}} = \frac{\frac{1}{2} CV^2}{3600 \times \text{mass}}$$

$$(4) E_{\text{max}} = \frac{\frac{1}{2} CV^2}{3600 \times \text{volume}} \quad (5) P_{\text{max}} = \frac{V^2}{4 \times \text{ESR}} \quad (6) P_{\text{max}} = \frac{V^2}{4 \times \text{ESR} \times \text{mass}}$$

$$(7) P_{\text{max}} = \frac{V^2}{4 \times \text{ESR} \times \text{volume}} \quad (8) I_{\text{max}} = \sqrt{\frac{\Delta T}{\text{ESR} \times R_{th}}}$$

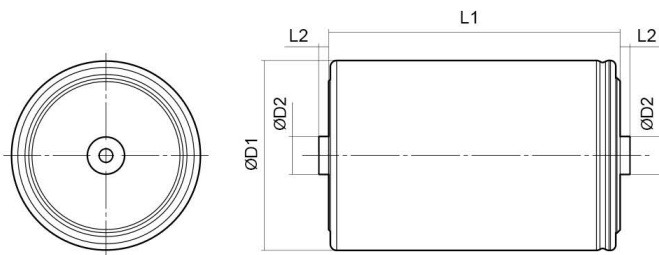

(9) The stated maximum peak current should not be exceeded during use. If the limit is to be exceeded by the customer, Skeleton must be consulted beforehand and give approval for the exceeded power load. Typical value represents the mean production sample value. Rated value represents the absolute minimum capacitance or maximum ESR value of production sample.

*Power values calculated using DC 10ms ESR = AC 100Hz.

Standard markings

- + Name of manufacturer, part number, serial number, rated voltage
- + Rated capacitance, negative and positive terminals, warning marking
- + Total energy in watt-hours
- + Electrolyte material used

Notes

- + Testing instructions available on www.skeletontech.com
- + All information provided on this data sheet and all subsequent ultracapacitors sales and testing are subject to Standard Terms of Service (ToS) available on www.skeletontech.com, document *General Terms of Sale for Skeleton Technologies GmbH*.

SkelCap

supercapacitor

The SkelCap supercapacitor series brings the benefits of our patented production technology to a form factor most commonly found in industry. These cells are developed for a variety of applications and offer very high power and excellent lifetime characteristics.

- + Capacitance 3000 F
- + Extreme power density
- + Durable and safe aluminum casings
- + Non-Threaded terminals
- + High cycle life >1,000,000 cycles
- + RoHS & UL810A compliant



General Specifications*	Value	Unit
Rated voltage V_R	2.85	V
Surge voltage V_s	3.0	V
Specific energy	6.7	Wh/kg
Nominal specific power	24	kW/kg
Practical specific power	18	kW/kg

Standards and certifications

Vibration Specification	ISO 16750-3, Table 12
Shock Resistance	IEC60068-2-27 Shock Test
Certifications	RoHS
Standards	REACH, UL 810A

General	Value	Unit
Product code	3710044	
Rated capacitance	3000	F
Total (5s) DC ESR, Rated at 150A	0.25	mΩ
DC 1s ESR, rated at 50A	0.22	mΩ
DC 10ms ESR, rated at 50A	0.17	mΩ
Maximum peak current, for 1 second ^{1,9}	2575	A

Energy

Energy ²	3.38	Wh
Specific energy ³	6.7	Wh/kg
Energy density ⁴	8.7	Wh/L

Temperature and Life

Operating temperature range

Minimum	-40	°C
Maximum	+65	°C

Storage temperature range (uncharged)

Minimum	-40	°C
Maximum	+50	°C

Life

Lifetime @ V_R and +65 °C Capacitance decrease 20% against rated value; 1s ESR increase 100% against rated value	1500	Hours
Storage life @ RT, uncharged	10	Years
Cyclelife @ RT, between V_R and $V_R/2$	1,000,000	Cycles

Power

Nominal power, calculated from 10 ms ESR (for comparison)

Specific power, matched Impedance ⁶	23.8	kW/kg
Power density, matched Impedance ⁷	30.6	kW/L

Practical power, calculated from 1 s ESR (for engineering)

Power, matched impedance ⁵	9.2	kW
Specific power, matched Impedance ⁶	18.4	kW/kg
Power density, matched impedance ⁷	23.7	kW/L

Safety

Short circuit current (For informational purposes - do not use as operating current.)	16.8	kA
---	------	----

Physical parameters	Value	Unit
Mass. Typical	0.50	kg
Volume	0.39	L
Diameter	60	mm
Length	138	mm

Thermal (based on DC 1s ESR)	Value	Unit
Thermal resistance, R_{ca} , typical	4	°C/W
Thermal capacitance, C_{th} , typical	0.58	kJ/°C
Max continuous current, $\Delta T = 15^{\circ}\text{C}^8$	131	A
Max continuous current, $\Delta T = 40^{\circ}\text{C}^8$	213	A

$$(1) \text{ Maximum peak current (1 sec)} = \frac{\frac{1}{2} CV}{C \times \text{ESR} + 1\text{s}} \quad (2) E_{\text{stored}} = \frac{\frac{1}{2} CV^2}{3600} \quad (3) E_{\text{max}} = \frac{\frac{1}{2} CV^2}{3600 \times \text{mass}}$$

$$(4) E_{\text{max}} = \frac{\frac{1}{2} CV^2}{3600 \times \text{volume}} \quad (5) P_{\text{max}} = \frac{V^2}{4 \times \text{ESR}} \quad (6) P_{\text{max}} = \frac{V^2}{4 \times \text{ESR} \times \text{mass}}$$

$$(7) P_{\text{max}} = \frac{V^2}{4 \times \text{ESR} \times \text{volume}} \quad (8) I_{\text{max}} = \sqrt{\frac{\Delta T}{\text{ESR} \times R_{th}}}$$

(9) The stated maximum peak current should not be exceeded during use. If the limit is to be exceeded by the customer, Skeleton must be consulted beforehand and give approval for the exceeded power load. Typical value represents the mean production sample value. Rated value represents the absolute minimum capacitance or maximum ESR value of production sample.

Standard markings

- + Name of manufacturer, part number, serial number, rated voltage
- + Rated capacitance, negative and positive terminals, warning marking
- + Total energy in watt-hours
- + Electrolyte material used

Notes

- + Testing instructions available on www.skeletontech.com
- + All information provided on this data sheet and all subsequent ultracapacitors sales and testing are subject to Standard Terms of Service (ToS) available on www.skeletontech.com, document General Terms of Sale for Skeleton Technologies GmbH.

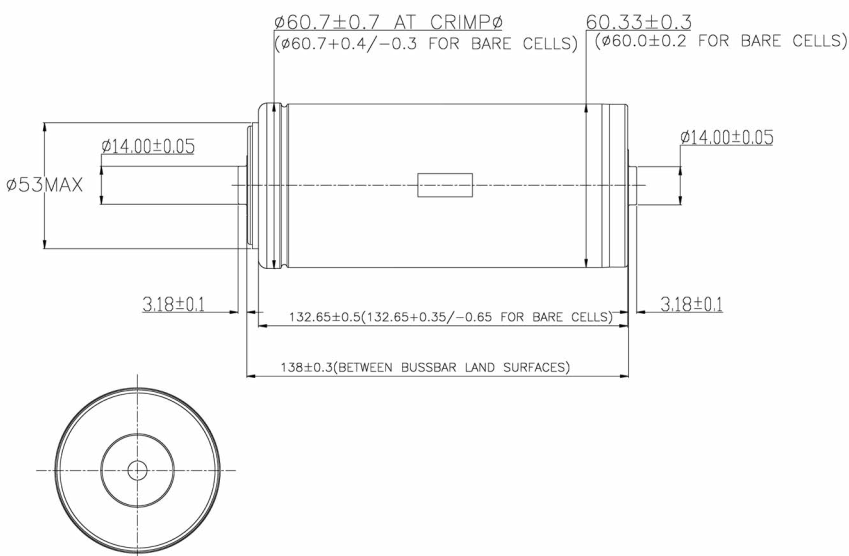

SkelCap

supercapacitor

The SkelCap supercapacitor series brings the benefits of our patented production technology to a form factor most commonly found in industry. These cells are developed for a variety of applications and offer very high power and excellent lifetime characteristics.

- + Capacitance 3400 F
- + Extreme power density
- + Durable and safe aluminum casings
- + Threaded terminals
- + High cycle life >1,000,000 cycles
- + RoHS & UL810A compliant



General Specifications*

Value	Unit
Rated voltage V_R	2.85 V
Surge voltage V_s	3.0 V
Specific energy	7.1 Wh/kg
Nominal specific power	22 kW/kg
Practical specific power	18 kW/kg

Standards and certifications

Vibration Specification	ISO 16750-3, Table 12
Shock Resistance	IEC60068-2-27 Shock Test
Certifications	RoHS
Standards	REACH, UL 810A

General

Value	Unit
Product code	3710047
Rated capacitance	3400 F
Total (5s) DC ESR, Rated at 150A	0.23 mΩ
DC 1s ESR, rated at 50A	0.21 mΩ
DC 10ms ESR, rated at 50A	0.17 mΩ
Maximum peak current, for 1 second ^{1,9}	2826 A

Energy

Energy ²	3.84 Wh
Specific energy ³	7.1 Wh/kg
Energy density ⁴	9.8 Wh/L

Temperature and Life

Value	Unit
Operating temperature range	
Minimum	-40 °C
Maximum	+65 °C
Storage temperature range (uncharged)	
Minimum	-40 °C
Maximum	+50 °C

Life

Lifetime @ V_R and +65 °C Capacitance decrease 20% against rated value; 1s ESR increase 100% against rated value	1500	Hours
Storage life @ RT, uncharged	10	Years
Cyclelife @ RT, between V_R and $V_R/2$	1,000,000	Cycles

Power

Nominal power, calculated from 10 ms ESR (for comparison)

Specific power, matched Impedance ⁶	22.1	kW/kg
Power density, matched Impedance ⁷	30.6	kW/L

Practical power, calculated from 1 s ESR (for engineering)

Power, matched impedance ⁵	9.7	kW
Specific power, matched Impedance ⁶	17.9	kW/kg
Power density, matched impedance ⁷	24.8	kW/L

Safety

Short circuit current (For informational purposes - do not use as operating current.)	16.8	kA
--	------	----

Physical parameters	Value	Unit
Mass. Typical	0.54	kg
Volume	0.39	L
Diameter	60	mm
Length	138	mm

Thermal (based on DC 1s ESR)	Value	Unit
Thermal resistance, R_{ca} , typical	3.35	°C/W
Thermal capacitance, C_{th} , typical	0.6	kJ/°C
Max continuous current, $\Delta T = 15^\circ C$ ⁸	143	A
Max continuous current, $\Delta T = 40^\circ C$ ⁸	233	A

$$(1) \text{ Maximum peak current (1 sec)} = \frac{\frac{1}{2} CV}{C \times ESR + 1s} \quad (2) E_{\text{stored}} = \frac{\frac{1}{2} CV^2}{3600} \quad (3) E_{\text{max}} = \frac{\frac{1}{2} CV^2}{3600 \times \text{mass}}$$

$$(4) E_{\text{max}} = \frac{\frac{1}{2} CV^2}{3600 \times \text{volume}} \quad (5) P_{\text{max}} = \frac{V^2}{4 \times ESR} \quad (6) P_{\text{max}} = \frac{V^2}{4 \times ESR \times \text{mass}}$$

$$(7) P_{\text{max}} = \frac{V^2}{4 \times ESR \times \text{volume}} \quad (8) I_{\text{max}} = \sqrt{\frac{\Delta T}{ESR \times R_{th}}}$$

(9) The stated maximum peak current should not be exceeded during use. If the limit is to be exceeded by the customer, Skeleton must be consulted beforehand and give approval for the exceeded power load. Typical value represents the mean production sample value. Rated value represents the absolute minimum capacitance or maximum ESR value of production sample.

Standard markings

- + Name of manufacturer, part number, serial number, rated voltage
- + Rated capacitance, negative and positive terminals, warning marking
- + Total energy in watt-hours
- + Electrolyte material used

Notes

- + Testing instructions available on www.skeletontech.com
- + All information provided on this data sheet and all subsequent ultracapacitors sales and testing are subject to Standard Terms of Service (ToS) available on www.skeletontech.com, document General Terms of Sale for Skeleton Technologies GmbH.

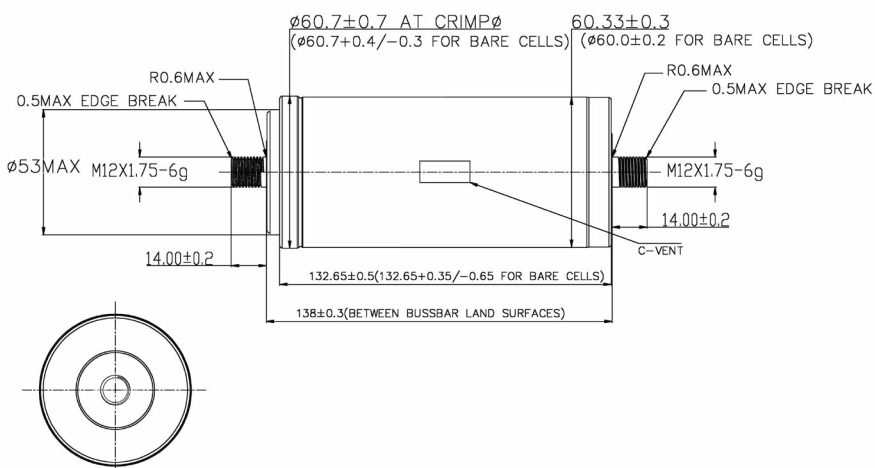

SkelCap⁺

supercapacitor

The SkelCap supercapacitor series brings the benefits of our patented production technology to a form factor most commonly found in industry. These cells are developed for a variety of applications and offer very high power and excellent lifetime characteristics.

- + Capacitance 3400 F
- + Extreme power density
- + Durable and safe aluminum casings
- + Non-Threaded terminals
- + High cycle life >1,000,000 cycles
- + RoHS & UL810A compliant



General Specifications*	Value	Unit
Rated voltage V_R	3.0	V
Surge voltage V_s	3.0	V
Specific energy	8.4	Wh/kg
Nominal specific power	26.0	kW/kg
Practical specific power	21.0	kW/kg

Standards and certifications

Vibration Specification	ISO 16750-3, Table 12
Shock Resistance	IEC60068-2-27 Shock Test
Certifications	RoHS
Standards	REACH, UL 810A

General	Value	Unit
Product code	3710045	
Rated capacitance	3400	F
DC 1s ESR, rated	0.21	m Ω
DC 10ms ESR, rated	0.17	m Ω
Maximum peak current, for 1 second ^{1,9}	3035	A

Energy

Energy ²	4.25	Wh
Specific energy ³	8.4	Wh/kg
Energy density ⁴	10.9	Wh/L

Temperature and Life	Value	Unit
Operating temperature range		
Minimum	-40	°C
Maximum	+65	°C

Storage temperature range (uncharged)		
Minimum	-40	°C
Maximum	+50	°C

Life	Value	Unit
Lifetime @ V_R and +65 °C Capacitance decrease 20% against rated value; 1s ESR increase 100% against rated value	1500	Hours
Storage life @ RT, uncharged	10	Years
Cyclelife @ RT, between V_R and $V_R/2$	1,000,000	Cycles

Power

Nominal power, calculated from 10 ms ESR (for comparison)		
Specific power, matched Impedance ⁶	26.0	kW/kg
Power density, matched Impedance ⁷	34.0	kW/L

Practical power, calculated from 1 s ESR (for engineering)		
Power, matched impedance ⁵	10.7	kW
Specific power, matched Impedance ⁶	21.0	kW/kg
Power density, matched impedance ⁷	27.5	kW/L

Safety	Value	Unit
Short circuit current (For informational purposes - do not use as operating current.)	18.8	kA

Physical parameters	Value	Unit
Mass, Typical	0.51	kg
Volume	0.39	L
Diameter	60	mm
Length	138	mm

Thermal (based on DC 1s ESR)	Value	Unit
Thermal resistance, R_{ca} , typical	3.35	°C/W
Thermal capacitance, C_{th} , typical	0.6	kJ/°C
Max continuous current, $\Delta T = 15^\circ C$ ⁸	150	A
Max continuous current, $\Delta T = 40^\circ C$ ⁸	244	A

$$(1) \text{ Maximum peak current (1 sec)} = \frac{\frac{1}{2} CV}{C \times ESR + 1s} \quad (2) E_{\text{stored}} = \frac{\frac{1}{2} CV^2}{3600} \quad (3) E_{\text{max}} = \frac{\frac{1}{2} CV^2}{3600 \times \text{mass}}$$

$$(4) E_{\text{max}} = \frac{\frac{1}{2} CV^2}{3600 \times \text{volume}} \quad (5) P_{\text{max}} = \frac{V^2}{4 \times ESR} \quad (6) P_{\text{max}} = \frac{V^2}{4 \times ESR \times \text{mass}}$$

$$(7) P_{\text{max}} = \frac{V^2}{4 \times ESR \times \text{volume}} \quad (8) I_{\text{max}} = \sqrt{\frac{\Delta T}{ESR \times R_{th}}}$$

(9) The stated maximum peak current should not be exceeded during use. If the limit is to be exceeded by the customer, Skeleton must be consulted beforehand and give approval for the exceeded power load. Typical value represents the mean production sample value. Rated value represents the absolute minimum capacitance or maximum ESR value of production sample.

Standard markings

- + Name of manufacturer, part number, serial number, rated voltage
- + Rated capacitance, negative and positive terminals, warning marking
- + Total energy in watt-hours
- + Electrolyte material used

Notes

- + Testing instructions available on www.skeletontech.com
- + All information provided on this data sheet and all subsequent ultracapacitors sales and testing are subject to Standard Terms of Service (ToS) available on www.skeletontech.com, document *General Terms of Sale for Skeleton Technologies GmbH*.

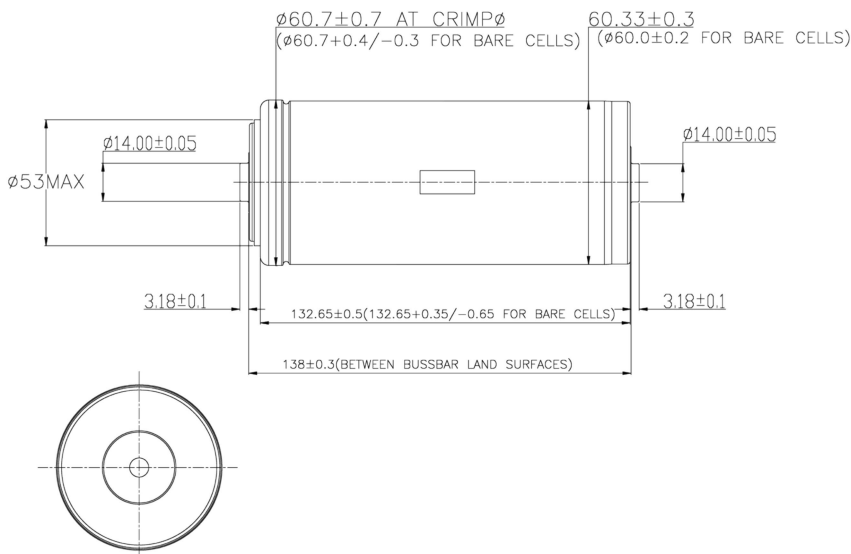

SkelCap

supercapacitor

- + Capacitance 5000 F
- + Extreme power density
- + Durable and safe aluminum casings
- + Weldable terminals
- + High cycle life >1,000,000 cycles
- + High temperature tolerance (operating and storage)
- + German quality
- + RoHS compliant



General	Value	Unit
Rated voltage V_R	3	V
Rated capacitance	5000	F
Initial capacitance, typical	5200	F
DC 10ms ESR rated	0.14	m Ω
DC 1s ESR rated	0.20	m Ω
ESR (IEC62391-1), rated	0.20	m Ω
Maximum peak current, for 1 second ^{1,9}	3.8	kA

Standards and certifications

Vibration Specification	ISO 16750-3, Table 12 Table 14
Certifications	RoHS

Physical parameters

Mass, typical (\pm 3-6 g, from small to large size)	0.565	kg
Volume	0.390	L
Diameter (\pm 0.2 mm, including label), D1	60.2	mm
Length (\pm 0.3 mm), L1	138	mm
Terminal diameter, D2	12	mm
Terminal length, L2	3.2	mm

Power	Value	Unit
Nominal power, calculated from 10ms ESR (for comparison)		
Power, matched impedance ⁵	16.1	kW
Specific power, matched impedance ⁶	28.4	kW/kg
Power density, matched impedance ⁷	41.2	kW/L

Nominal power, calculated from 1s ESR (for engineering)		
Power, matched impedance ⁵	11.2	kW
Specific power, matched impedance ⁶	19.9	kW/kg
Power density, matched impedance ⁷	28.9	kW/L

Temperature and Life

Operating temperature range

Minimum	-40	$^{\circ}$ C
Maximum	+65	$^{\circ}$ C

Storage temperature range (uncharged)

Minimum	-40	$^{\circ}$ C
Maximum	+50	$^{\circ}$ C

Life

Capacitance decrease 20% from rated value;
resistance increase 100% from rated value

Storage life @ RT, uncharged	10	Years
Cyclelife @ RT, between V_R and $V_R/2$	1,000,000	Cycles

Energy	Value	Unit
Energy ²	6.3	Wh
Specific energy ³	11.1	Wh/kg
Energy density ⁴	16.0	Wh/L

Safety

Short circuit current (For informational purposes - do not use as operating current.)	21.4	kA
---	------	----

Thermal (based on DC 1s ESR)	Value	Unit
Thermal resistance given $\Delta T = 30^{\circ}\text{C}$, R_{th}	3	$^{\circ}\text{C}/\text{W}$
Thermal capacitance, C_{th} , typical	634	$\text{J}/^{\circ}\text{C}$
Max continuous current ¹⁰ , $\Delta T = 15^{\circ}\text{C}$ ⁸	158	A
Max continuous current ¹⁰ , $\Delta T = 30^{\circ}\text{C}$ ⁸	224	A
Max continuous current ¹⁰ , $\Delta T = 40^{\circ}\text{C}$ ⁸	258	A

$$(1) \text{ Maximum peak current (1 sec)} = \frac{\frac{1}{2} CV}{C \times \text{ESR} + 1\text{s}} \quad (2) E_{\text{stored}} = \frac{\frac{1}{2} CV^2}{3600} \quad (3) E_{\text{max}} = \frac{\frac{1}{2} CV^2}{3600 \times \text{mass}}$$

$$(4) E_{\text{max}} = \frac{\frac{1}{2} CV^2}{3600 \times \text{volume}} \quad (5) P_{\text{max}} = \frac{V^2}{4 \times \text{ESR}} \quad (6) P_{\text{max}} = \frac{V^2}{4 \times \text{ESR} \times \text{mass}}$$

$$(7) P_{\text{max}} = \frac{V^2}{4 \times \text{ESR} \times \text{volume}} \quad (8) I_{\text{max}} = \sqrt{\frac{\Delta T}{\text{ESR} \times R_{th}}}$$

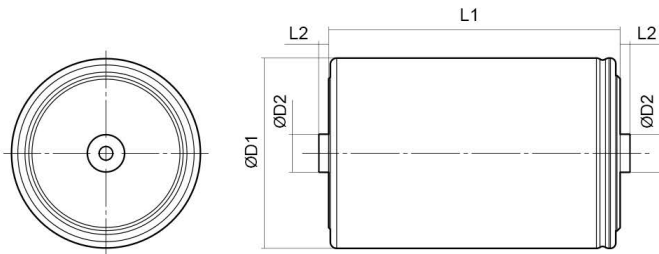

(9) The stated maximum peak current should not be exceeded during use. If the limit is to be exceeded by the customer, Skeleton must be consulted beforehand and give approval for the exceeded power load. Typical value represents the mean production sample value. Rated value represents the absolute minimum capacitance or maximum ESR value of production sample.

*Power values calculated using DC 10ms ESR = AC 100Hz.

Standard markings

- + Name of manufacturer, part number, serial number, rated voltage
- + Rated capacitance, negative and positive terminals, warning marking
- + Total energy in watt-hours
- + Electrolyte material used

Notes

- + Testing instructions available on www.skeletontech.com
- + All information provided on this data sheet and all subsequent ultracapacitors sales and testing are subject to Standard Terms of Service (ToS) available on www.skeletontech.com, document *General Terms of Sale for Skeleton Technologies GmbH*.