

**SKELETON**  
TECHNOLOGIES

# SkelCap

supercapacitor

SCK3000 (weldable terminals)

SCL3000 and SCI3400 (threaded terminals)



# SkelCap

## supercapacitor

The SkelCap supercapacitor series brings the benefits of our patented production technology to a form factor most commonly found in industry. These cells are developed for a variety of applications and offer very high power and excellent lifetime characteristics.

- + Capacitance 3000 F
- + Extreme power density
- + Durable and safe aluminum casings
- + Non-Threaded terminals
- + High cycle life >1,000,000 cycles
- + RoHS & UL810A compliant



General Specifications*	Value	Unit
Rated voltage $V_R$	2.85	V
Surge voltage $V_s$	3.0	V
Specific energy	6.7	Wh/kg
Nominal specific power	24	kW/kg
Practical specific power	18	kW/kg

### Standards and certifications

Vibration Specification	ISO 16750-3, Table 12
Shock Resistance	IEC60068-2-27 Shock Test
Certifications	RoHS
Standards	REACH, UL 810A

General	Value	Unit
Product code	3710044	
Rated capacitance	3000	F
Total (5s) DC ESR, Rated at 150A	0.25	mΩ
DC 1s ESR, rated at 50A	0.22	mΩ
DC 10ms ESR, rated at 50A	0.17	mΩ
Maximum peak current, for 1 second <sup>1,9</sup>	2575	A

### Energy

Energy <sup>2</sup>	3.38	Wh
Specific energy <sup>3</sup>	6.7	Wh/kg
Energy density <sup>4</sup>	8.7	Wh/L

Temperature and Life	Value	Unit
----------------------	-------	------

### Operating temperature range

Minimum	-40	°C
Maximum	+65	°C

### Storage temperature range (uncharged)

Minimum	-40	°C
Maximum	+50	°C

### Life

Lifetime @ $V_R$ and +65 °C Capacitance decrease 20% against rated value; 1s ESR increase 100% against rated value	1500	Hours
Storage life @ RT, uncharged	10	Years
Cyclelife @ RT, between $V_R$ and $V_R/2$	1,000,000	Cycles

### Power

#### Nominal power, calculated from 10 ms ESR (for comparison)

Specific power, matched Impedance <sup>6</sup>	23.8	kW/kg
Power density, matched Impedance <sup>7</sup>	30.6	kW/L

#### Practical power, calculated from 1 s ESR (for engineering)

Power, matched impedance <sup>5</sup>	9.2	kW
Specific power, matched Impedance <sup>6</sup>	18.4	kW/kg
Power density, matched impedance <sup>7</sup>	23.7	kW/L

### Safety

Short circuit current (For informational purposes - do not use as operating current.)	16.8	kA
---	------	----

Physical parameters	Value	Unit
Mass. Typical	0.50	kg
Volume	0.39	L
Diameter	60	mm
Length	138	mm

Thermal (based on DC 1s ESR)	Value	Unit
Thermal resistance, $R_{ca}$ , typical	4	°C/W
Thermal capacitance, $C_{th}$ , typical	0.58	J/°C
Max continuous current, $\Delta T = 15^\circ C$ <sup>8</sup>	131	A
Max continuous current, $\Delta T = 40^\circ C$ <sup>8</sup>	213	A

$$(1) \text{ Maximum peak current (1 sec)} = \frac{\frac{1}{2} CV}{C \cdot ESR + 1s} \quad (2) E_{\text{stored}} = \frac{\frac{1}{2} CV^2}{3600} \quad (3) E_{\text{max}} = \frac{\frac{1}{2} CV^2}{3600 \times \text{mass}}$$

$$(4) E_{\text{max}} = \frac{\frac{1}{2} CV^2}{3600 \times \text{volume}} \quad (5) P_{\text{max}} = \frac{V^2}{4 \times ESR} \quad (6) P_{\text{max}} = \frac{V^2}{4 \times ESR \times \text{mass}}$$

$$(7) P_{\text{max}} = \frac{V^2}{4 \times ESR \times \text{volume}} \quad (8) I_{\text{max}} = \sqrt{\frac{\Delta T}{ESR \times R_{th}}}$$

(9) The stated maximum peak current should not be exceeded during use. If the limit is to be exceeded by the customer, Skeleton must be consulted beforehand and give approval for the exceeded power load. Typical value represents the mean production sample value. Rated value represents the absolute minimum capacitance or maximum ESR value of production sample.

### Standard markings

- + Name of manufacturer, part number, serial number, rated voltage
- + Rated capacitance, negative and positive terminals, warning marking
- + Total energy in watt-hours
- + Electrolyte material used

### Notes

- + Testing instructions available on [www.skeletontech.com](http://www.skeletontech.com)
- + All information provided on this data sheet and all subsequent ultracapacitors sales and testing are subject to Standard Terms of Service (ToS) available on [www.skeletontech.com](http://www.skeletontech.com), document *General Terms of Sale for Skeleton Technologies GmbH*.

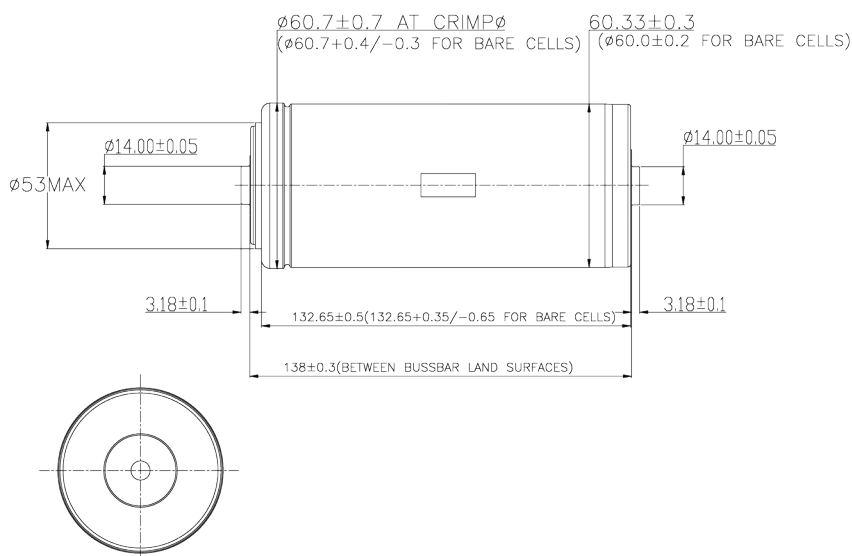

# SkelCap

## supercapacitor

The SkelCap supercapacitor series brings the benefits of our patented production technology to a form factor most commonly found in industry. These cells are developed for a variety of applications and offer very high power and excellent lifetime characteristics.

- + Capacitance 3000 F
- + Extreme power density
- + Durable and safe aluminum casings
- + Non-Threaded terminals
- + High cycle life >1,000,000 cycles
- + RoHS & UL810A compliant



### General Specifications\*

	Value	Unit
Rated voltage $V_R$	2.85	V
Surge voltage $V_s$	3.0	V
Specific energy	6.4	Wh/kg
Nominal specific power	21	kW/kg
Practical specific power	17	kW/kg

### Standards and certifications

Vibration Specification	ISO 16750-3, Table 12
Shock Resistance	IEC60068-2-27 Shock Test
Certifications	RoHS
Standards	REACH, UL 810A

### General

	Value	Unit
Product code	3710046	
Rated capacitance	3000	F
Total (5s) DC ESR, Rated at 150A	0.26	m $\Omega$
DC 1s ESR, rated at 50A	0.23	m $\Omega$
DC 10ms ESR, rated at 50A	0.18	m $\Omega$
Maximum peak current, for 1 second <sup>1,9</sup>	2529	A

### Energy

Energy <sup>2</sup>	3.38	Wh
Specific energy <sup>3</sup>	6.4	Wh/kg
Energy density <sup>4</sup>	8.7	Wh/L

### Temperature and Life

	Value	Unit
<b>Operating temperature range</b>		
Minimum	-40	°C
Maximum	+65	°C
<b>Storage temperature range (uncharged)</b>		
Minimum	-40	°C
Maximum	+50	°C

### Life

Lifetime @ $V_R$ and +65 °C Capacitance decrease 20% against rated value; 1s ESR increase 100% against rated value	1500	Hours
Storage life @ RT, uncharged	10	Years
Cyclelife @ RT, between $V_R$ and $V_R/2$	1,000,000	Cycles

### Power

#### Nominal power, calculated from 10 ms ESR (for comparison)

Specific power, matched Impedance <sup>6</sup>	21.3	kW/kg
Power density, matched Impedance <sup>7</sup>	28.9	kW/L

#### Practical power, calculated from 1 s ESR (for engineering)

Power, matched impedance <sup>5</sup>	8.8	kW
Specific power, matched Impedance <sup>6</sup>	16.7	kW/kg
Power density, matched impedance <sup>7</sup>	22.6	kW/L

### Safety

Short circuit current (For informational purposes - do not use as operating current.)	15.9	kA
---	------	----

Physical parameters	Value	Unit
Mass. Typical	0.53	kg
Volume	0.39	L
Diameter	60	mm
Length	138	mm

Thermal (based on DC 1s ESR)	Value	Unit
Thermal resistance, $R_{ca}$ , typical	4.1	$^{\circ}\text{C}/\text{W}$
Thermal capacitance, $C_{th}$ , typical	0.58	$\text{J}/^{\circ}\text{C}$
Max continuous current, $\Delta T = 15^{\circ}\text{C}^{\text{§}}$	126	A
Max continuous current, $\Delta T = 40^{\circ}\text{C}^{\text{§}}$	206	A

$$(1) \text{ Maximum peak current (1 sec)} = \frac{\frac{1}{2} CV}{C \cdot \text{ESR} + 1\text{s}} \quad (2) E_{\text{stored}} = \frac{\frac{1}{2} CV^2}{3600} \quad (3) E_{\text{max}} = \frac{\frac{1}{2} CV^2}{3600 \times \text{mass}}$$

$$(4) E_{\text{max}} = \frac{\frac{1}{2} CV^2}{3600 \times \text{volume}} \quad (5) P_{\text{max}} = \frac{V^2}{4 \times \text{ESR}} \quad (6) P_{\text{max}} = \frac{V^2}{4 \times \text{ESR} \times \text{mass}}$$

$$(7) P_{\text{max}} = \frac{V^2}{4 \times \text{ESR} \times \text{volume}} \quad (8) I_{\text{max}} = \sqrt{\frac{\Delta T}{\text{ESR} \times R_{th}}}$$

(9) The stated maximum peak current should not be exceeded during use. If the limit is to be exceeded by the customer, Skeleton must be consulted beforehand and give approval for the exceeded power load. Typical value represents the mean production sample value. Rated value represents the absolute minimum capacitance or maximum ESR value of production sample.

#### Standard markings

- + Name of manufacturer, part number, serial number, rated voltage
- + Rated capacitance, negative and positive terminals, warning marking
- + Total energy in watt-hours
- + Electrolyte material used

#### Notes

- + Testing instructions available on [www.skeleontech.com](http://www.skeleontech.com)
- + All information provided on this data sheet and all subsequent ultracapacitors sales and testing are subject to Standard Terms of Service (ToS) available on [www.skeleontech.com](http://www.skeleontech.com), document General Terms of Sale for Skeleton Technologies GmbH.

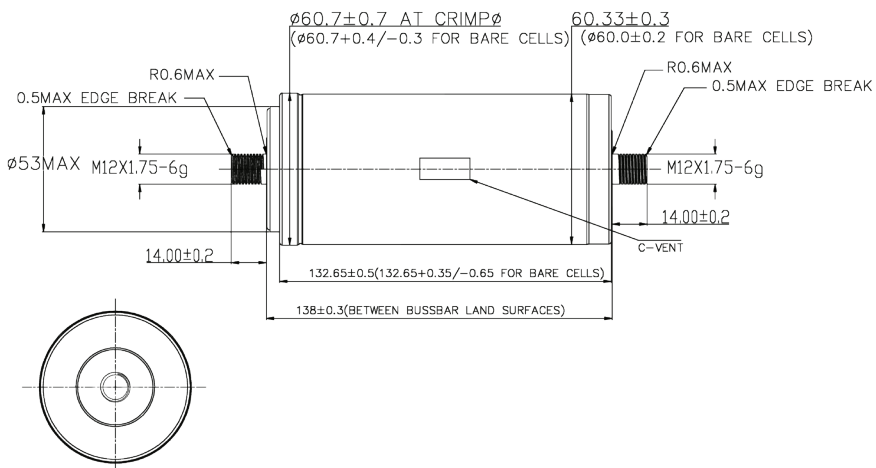

# SkelCap

## supercapacitor

The SkelCap supercapacitor series brings the benefits of our patented production technology to a form factor most commonly found in industry. These cells are developed for a variety of applications and offer very high power and excellent lifetime characteristics.

- + Capacitance 3400 F
- + Extreme power density
- + Durable and safe aluminum casings
- + Non-Threaded terminals
- + High cycle life >1,000,000 cycles
- + RoHS & UL810A compliant



General Specifications*	Value	Unit
Rated voltage $V_R$	2.85	V
Surge voltage $V_s$	3.0	V
Specific energy	7.1	Wh/kg
Nominal specific power	22	kW/kg
Practical specific power	18	kW/kg

### Standards and certifications

Vibration Specification	ISO 16750-3, Table 12
Shock Resistance	IEC60068-2-27 Shock Test
Certifications	RoHS
Standards	REACH, UL 810A

General	Value	Unit
Product code	3710047	
Rated capacitance	3400	F
Total (5s) DC ESR, Rated at 150A	0.23	m $\Omega$
DC 1s ESR, rated at 50A	0.21	m $\Omega$
DC 10ms ESR, rated at 50A	0.17	m $\Omega$
Maximum peak current, for 1 second <sup>1,9</sup>	2826	A

### Energy

Energy <sup>2</sup>	3.84	Wh
Specific energy <sup>3</sup>	7.1	Wh/kg
Energy density <sup>4</sup>	9.8	Wh/L

Temperature and Life	Value	Unit
----------------------	-------	------

### Operating temperature range

Minimum	-40	°C
Maximum	+65	°C

### Storage temperature range (uncharged)

Minimum	-40	°C
Maximum	+50	°C

### Life

Lifetime @ $V_R$ and +65 °C Capacitance decrease 20% against rated value; 1s ESR increase 100% against rated value	1500	Hours
Storage life @ RT, uncharged	10	Years
Cyclelife @ RT, between $V_R$ and $V_R/2$	1,000,000	Cycles

### Power

#### Nominal power, calculated from 10 ms ESR (for comparison)

Specific power, matched Impedance <sup>6</sup>	22.1	kW/kg
Power density, matched Impedance <sup>7</sup>	30.6	kW/L

#### Practical power, calculated from 1 s ESR (for engineering)

Power, matched impedance <sup>5</sup>	9.7	kW
Specific power, matched Impedance <sup>6</sup>	17.9	kW/kg
Power density, matched impedance <sup>7</sup>	24.8	kW/L

### Safety

Short circuit current (For informational purposes - do not use as operating current.)	16.8	kA
---	------	----

Physical parameters	Value	Unit
Mass, Typical	0.54	kg
Volume	0.39	L
Diameter	60	mm
Length	138	mm

Thermal (based on DC 1s ESR)	Value	Unit
Thermal resistance, $R_{ca}$ , typical	3.35	°C/W
Thermal capacitance, $C_{th}$ , typical	0.6	J/°C
Max continuous current, $\Delta T = 15^\circ C$ <sup>8</sup>	143	A
Max continuous current, $\Delta T = 40^\circ C$ <sup>8</sup>	233	A

$$(1) \text{ Maximum peak current (1 sec)} = \frac{\frac{1}{2} CV}{C \times ESR + 1s} \quad (2) E_{\text{stored}} = \frac{\frac{1}{2} CV^2}{3600} \quad (3) E_{\text{max}} = \frac{\frac{1}{2} CV^2}{3600 \times \text{mass}}$$

$$(4) E_{\text{max}} = \frac{\frac{1}{2} CV^2}{3600 \times \text{volume}} \quad (5) P_{\text{max}} = \frac{V^2}{4 \times ESR} \quad (6) P_{\text{max}} = \frac{V^2}{4 \times ESR \times \text{mass}}$$

$$(7) P_{\text{max}} = \frac{V^2}{4 \times ESR \times \text{volume}} \quad (8) I_{\text{max}} = \sqrt{\frac{\Delta T}{ESR \times R_{th}}}$$

(9) The stated maximum peak current should not be exceeded during use. If the limit is to be exceeded by the customer, Skeleton must be consulted beforehand and give approval for the exceeded power load. Typical value represents the mean production sample value. Rated value represents the absolute minimum capacitance or maximum ESR value of production sample.

### Standard markings

- + Name of manufacturer, part number, serial number, rated voltage
- + Rated capacitance, negative and positive terminals, warning marking
- + Total energy in watt-hours
- + Electrolyte material used

### Notes

- + Testing instructions available on [www.skeletontech.com](http://www.skeletontech.com)
- + All information provided on this data sheet and all subsequent ultracapacitors sales and testing are subject to Standard Terms of Service (ToS) available on [www.skeletontech.com](http://www.skeletontech.com), document General Terms of Sale for Skeleton Technologies GmbH.

